

# Potato Halver System

The Farmco [Potato Halver](#) cuts too-long potatoes in half crosswise, so that french-fry processors can simply and efficiently increase yield, achieve length specifications, and prevent product length-related packaging problems.

The Potato Halver System accepts full line-flow potatoes onto a Farmco [Flite Roller Table](#) to evenly spread product. Next, potatoes move to a [Diameter Sizer](#) where small-diameter product is separated. Large-diameter potatoes divert to an Upright Length Sizer, which removes short potatoes and transfers long potatoes to the Potato Halver unit for crosswise cutting. The system can be laid out so that all potatoes - including halved potatoes - discharge onto the same conveyor for further processing.



In plant operation, the Potato Halver unit typically cuts between 320 and 360 potatoes per minute. Each halving lane includes vertical-lift holding pockets, a device to center potatoes in the pockets before cutting, and a rotating circular knife cutting mechanism. The cutting lanes are fed by an integral, angled cross-feed conveyor. The Potato Halver achieves greatest efficiency when used in conjunction with the Farmco Flite Roller Table, Diameter Sizer, and Length Sizer; and Key vibratory conveyors.



## Benefits

- Accurate sizing
  - In-plant fine-tuning
  - Simplifies achieving grade specifications
- Rapid payback
  - Achieves highest-value end product
  - High capacity
  - Improves yields and quality
- Minimum waste or reprocessing
- Economical to install and operate
- Easy to operate and maintain
- Adaptable to plant layout
- Seamless integration with other Farmco equipment, [Iso-Flo vibratory conveyors](#), and [ADR automatic defect removal systems](#) for potato strips

Key Technology BV

Beijerdstraat 10, 4112 NE Beusichem, The Netherlands

Phone: +31 0 345-50 9900 • Fax: +31 0 345-50 1594 • [keybv@key.net](mailto:keybv@key.net) • [www.key.net](http://www.key.net)



## Specifications/Information on Potato Halver Unit

- Capacity: Up to 320 to 360 potatoes per minute typical
- Very few mis-cuts
- Sizing: Up to four halving lanes with fifth lane transferring carryovers into line flow
- Dimensions:
  - Overall length: 3200 mm
  - Overall width: 1448 mm
  - Overall height: 1930 mm
- Construction: stainless steel, food-grade plastic, food-grade plastic mesh cross-feed conveyor
- Motors
  - Standard: 230/460V, 60 Hz, 3-phase
  - Other motor specifications available

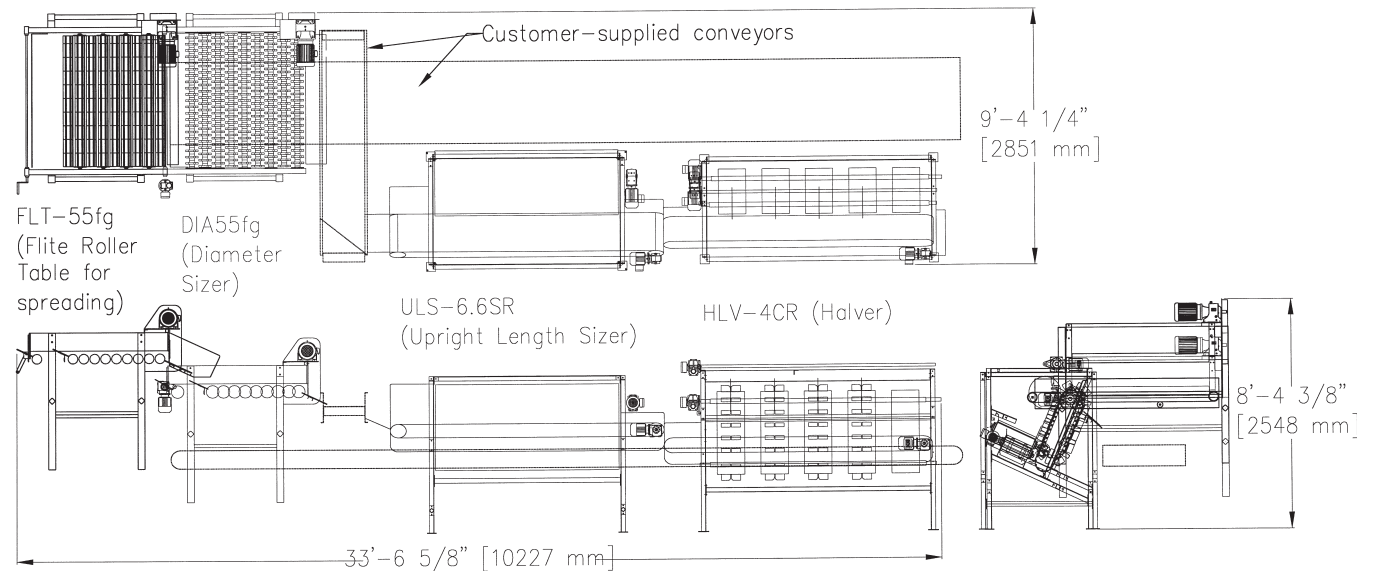

## Suggested System Layout

(Machine placement can vary based on layout and space requirements)