

Innovations for Winemakers

Simply the best

For over 50 years, Key Technology has been designing and manufacturing innovative, practical equipment for the food processing industry. Now Key's processing expertise can help you improve the efficiency of your winery operation and the quality of your final product.

Continuous-flow automation

Key's automated **Wine Grape Inspection Shaker** helps you put only flawless berries behind your label... not leaves, bugs, raisined clusters or other MOG (Material Other than Grapes). MOG should not be allowed to interfere with your signature wine chemistry. Inspecting with Key's gentle and reliable vibratory shaker enables you to achieve impressive efficiency while producing a wine of impeccable quality.



You can depend on Key's Wine Grape Inspection Shaker, part of the world-renowned family of Iso-Flo® Vibratory Conveying Systems, to stand up to your most rigorous workouts. With over 25,000 Iso-Flo® conveying systems installed around the world, Key knows how to provide you with the perfect solution for your processing needs.

This specialized, maintenance-free vibratory shaker from the Iso-Flo® family displays grapes evenly as they progress to the destemmer/crusher at an ideal speed for spotting and removing undesirable fruit and field debris from the must. The shaker features ergonomic design with integrated, non-vibrating support rails; stainless steel construction for easy, complete sanitation; and adjustable height for feeding downstream equipment of any make or size. The inverter option provides easy speed adjustability and control.

Benefits

- Displays product for easy removal of unwanted material
- Gently and evenly moves grapes to destemmer for increased efficiency
- Prevents crushing, bruising or tannin release
- Works reliably 24/7 - without maintenance
- Two-year warranty
- Capacity from 1-10 tons per hour
- Maximizes operator comfort with ergonomic support rails
- Adjusts easily to any height and moves easily on casters
- Easy to clean; no cracks, crevices, or laminations
- Fast and effortless changeover between varieties



Key Technology BV

Beijerdstraat 10, 4112 NE Beusichem, The Netherlands

Phone: +31 0 345-50 9900 • Fax: +31 0 345-50 1594 • keybv@key.net • www.key.net



Other Winemaking Equipment from Key

Impulse™ Electromagnetic Conveyor - another vibratory option to evenly spread product accommodating manual inspection and further protecting the product from being crushed under the weight of other grapes. Grapes are gently moved to the de-stemmer crusher minimizing bruising and release of tannins. With the touch-of-a-button, wine processors can adjust product flow control for instant start/stop and precise metering to prevent overloading the de-stemmer crusher.

Belt Conveyor - Key's belt conveyor accommodates high capacity feeding to the inspection shaker for manual inspection. With head loads up to 4000 pounds, belt conveyors can hold several totes of product at once. Gates at the end of the belt knock excess product back onto the belt to control the rate of product flow.

2X Air Cleaner - for removal of debris, fines and leaves, especially when grapes have been mechanically picked. Using a positive air flow design and Iso-Flo inspection shakers, the system removes 98 percent of all light trash during normal processing conditions. You'll save costs by reducing manual inspection and simplifying cleaning.

More Processing Solutions

- Rejected Material Trough
- Jack Removal Shaker
- Jack Inspection Shaker
- Bin Dumper

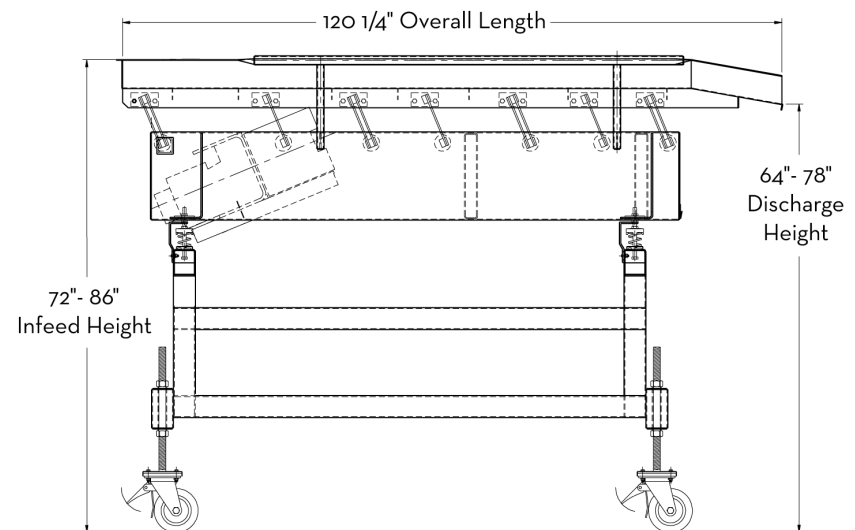
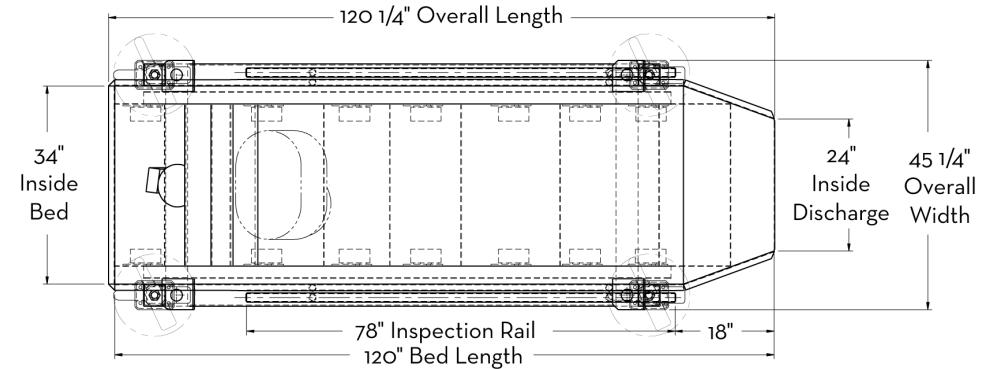

Typical Wine Grape Inspection Shaker

Hear what other vintners are saying:

"We couldn't have asked for more. The new sorting shaker proved outstanding. It allowed us to hand-sort our crop to eliminate any foreign objects or clusters that were not of optimum quality."

Norm McKibben, Pepper Bridge Winery

"We've seen destemming performance improve, just from controlling the feed rate by using the Iso-Flo®."

California winemaker

"The varietal changeover from cabernet to merlot is simple; the shaker is very easy to clean."

Washington winemaker